



An IMCI Company
BIJUR DELIMON[®]
INTERNATIONAL



EXACTOSERVE[™] COMPONENTS

PUMPS, INJECTORS, CONTROLLERS

BULLETIN 414

Contents

Introduction	2-4
Grease Injectors	5-8
Oil Injectors.....	9-12
Injector Accessories.....	13-15
Manual Grease Pumps	16
Air-Operated Grease Pumps	17-19
Electric Grease Drum Pumps	20
Air-Operated Oil Pumps.....	21-22
Electric Oil Pumps	23
Electric Grease Pumps	24
System Controllers	25-27
Solenoid Valves.....	28
Injector & Bearing Point Monitors ..	29-30
Pump Accessories.....	31
Tubing & Fittings.....	32
Notes.....	33-34

INSURES ACCURATE
LUBRICATION ·
ELIMINATES LUBRICANT
CONTAMINATION · EASILY
EXPANDABLE · PREVENTS
PERSONAL INJURY
HAZARDS · PROLONGS
MACHINE LIFE · REDUCES
REPAIRS AND DOWNTIME

Illustrations and specifications are not binding in detail. Designs are subject to modification and improvement without notice.

Introduction

ExactoServe lubricating systems are found in virtually every industry in which continuous duty operation is required. From canning and bottling to pulp and paper, from mining equipment to machine tools, automatic application of the lubricant provides significant benefits to the equipment user. There are several components that are used in designing an ExactoServe system:

- + Positive Displacement Injectors
- + Pump Units (Oil or Grease)
- + Vent Valve
- + Controllers

Positive Displacement Injectors

Injectors are the heart of ExactoServe lubrication systems. They are mounted close to the lubrication points and are hydraulically operated by pressure from the supply line. On each pressurization cycle, they discharge fixed volumes of lubricant to the bearing or lubrication point.

Pump Units (Oil or Grease)

Manual, pneumatic and electric pump units store and pump lubricant to injectors throughout the system.

Vent Valves

These valves relieve the system pressure, which causes injectors in the system to reload for next lube cycle.

Controllers

Programmable controllers give you access to key system functions, such as system on and off, and can control what happens when there is a problem in the system.

Advantages of ExactoServe Systems

- + Lubrication points can be added easily without redesigning the total system.
- + A blockage between injector and bearing will not shut the system down; remaining bearings will continue to be lubricated.
- + There are positive lubrication indicators for each bearing point.
- + They have the ability to positively displace a broad range of lubricants from light oil to #2 grease.
- + Lubrication discharge volume at each bearing is fully adjustable even after start-up.

Introduction

Simplicity

ExactoServe systems use a single supply line to feed all injectors from an individual pump. On large or multiple machine installations, careful design of the supply lines and use of manifold injectors can create a system of minimal complexity and cost.

The adjustable injectors make it easy to fine tune the system. Injectors can often be adjusted or replaced between cycles, meaning simple maintenance tasks won't interrupt operation.

Reliability

A lubrication system is your equipment's life support system. It prevents failure. It must be totally reliable. That's why ExactoServe, like all BDI products, meets the highest standards of trouble-free performance.

ExactoServe components are ruggedly constructed and withstand extreme industrial environments.

The system's distribution lines are totally sealed from pump to injector, meaning dirt or dust will not contaminate the lubricant. By maintaining clean oil or grease in the system reservoir you can ensure maximum machinery protection.

Principle of Operation

ExactoServe systems work on a two-stage cycle: pressure buildup and system vent.

At the heart of the system is a pump and central reservoir. Under pressure, grease or oil moves through supply lines to the injectors.

To trigger the injectors, system pressure builds up rapidly during the pressure cycle, forcing injector discharge. Pressure is then vented, allowing the injectors to reset for the next cycle.

The Right System

BDI offers a system to match your machine's requirement to your budget. Choose from:

Manual lubricators offer an affordable solution for small machines. An operator pressurizes a manual system by working a pump handle. Once the injectors discharge, the operator manually vents the system pressure. This action resets the system for the next cycle.

Air-driven lubricators operate on compressed shop air. After injector discharge, air-driven systems are automatically vented and reset. Cycle time is set by a built-in or external controller.

BDI's drum pumps are high capacity air-driven lubricators used for larger grease systems. Drum pumps require a separate controller and vent valve.

BDI electric motor driven pumps are used where compressed air is not available, or electrical operation is preferred. Time control is adjustable to provide predetermined frequency of lubrication.

Putting the system together

The final system may include an external controller. BDI's SS2200 and SC400 programmable controllers will control cycle times for any system.

Other system components include timers, gauges, grease strainers, flexible hose and brushes.

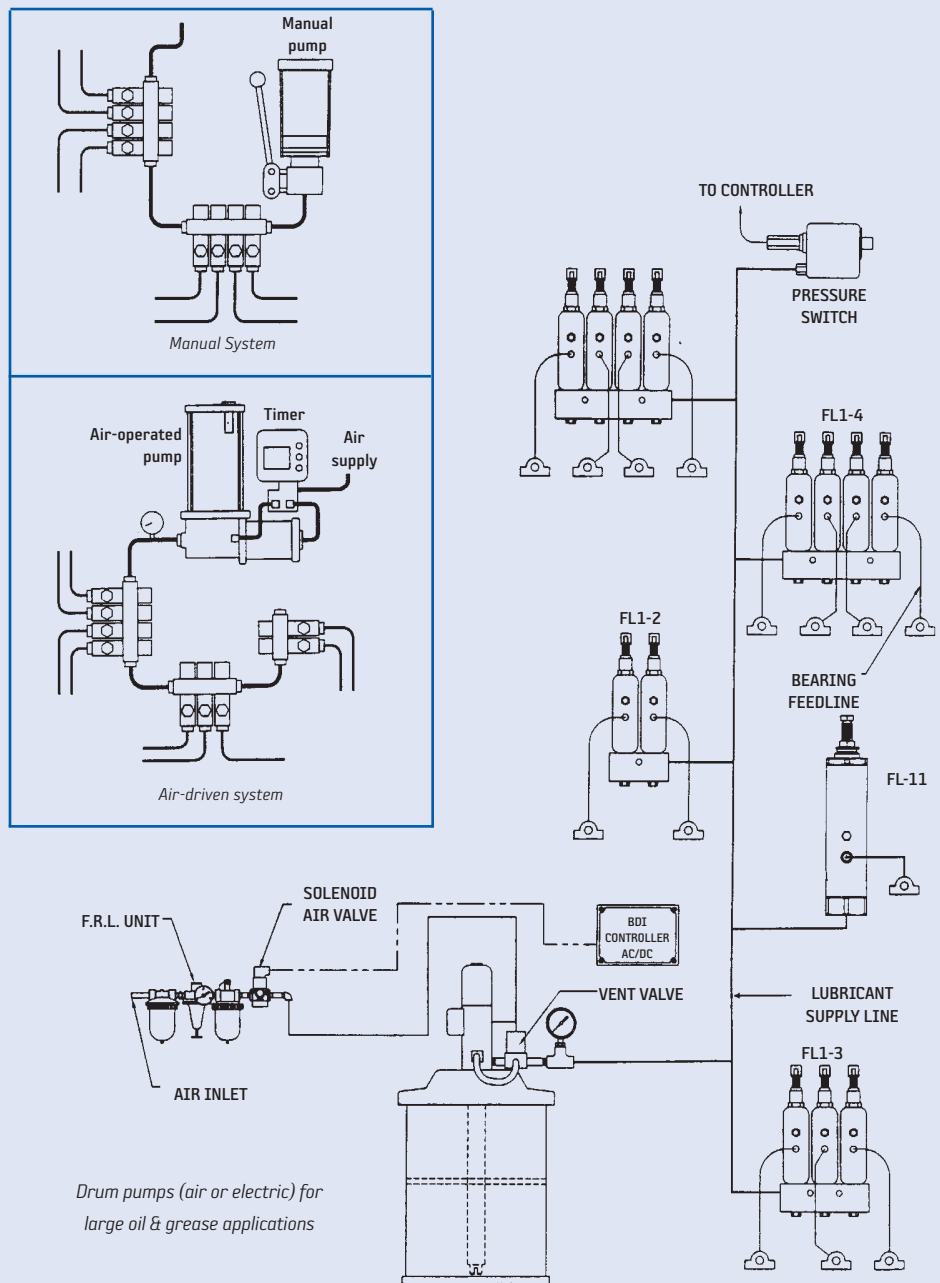

Drum pumps (air or electric) for large oil & grease applications

Introduction

Injector Operating Sequence

BDI injectors can be adjusted to dispense the amount of lube each bearing requires. Injectors are typically mounted in a manifold with feedlines supplying lube to the bearings. Injectors are supplied with oil/grease via a pump through a lube supply line.

FL-1, -11, -44, -45

(1) Under pump pressure lube enters injector inlet (2) Slide valve is lifted allowing lube flow into channel and to top of piston (3) As incoming pressure moves piston down, a metered amount of lube is discharged out of injector outlet (4) When lube cycle is completed and pump stops, the system pressure is vented/relieved through vent valve allowing piston spring to retract forcing lube back down channel and into cross drilled port in slide valve, this places a metered amount of lube in discharge chamber for the next cycle.

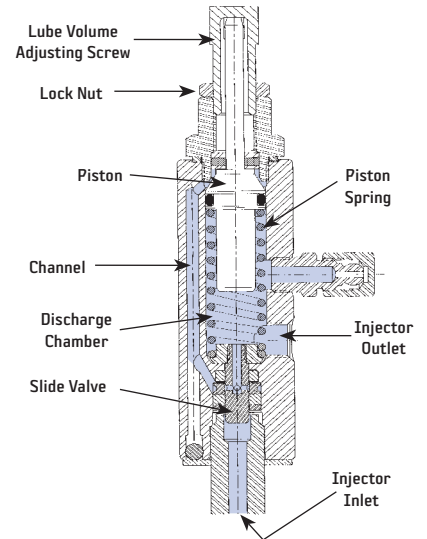

FL-1, -11, -44, -45 Injector Output Adjustment

Minimum output is achieved by loosening lock nut and hand tighten adjustment screw
 Maximum output is 10 turns from minimum setting at approx. .008 cu. in. per turn for FL-1, 44 and .040 cu. in. per turn for FL-11, 45

Note: Always verify flow at minimum setting.

FL-32, -33, -42, -43

Pressure stage - Pressure from the supply line moves the plunger forward. This forces a pre-measured amount of lubricant (delivered during previous vent stage) out of the discharge chamber outlet. At the same time, lubricant is transferred into the measuring chamber - the indicator stem extends as this chamber fills.

Vent stage - System pressure is vented. The plunger retracts to its original position. This movement allows lubricant stored in the measuring chamber to empty into the discharge chamber; the indicator stem retracts.

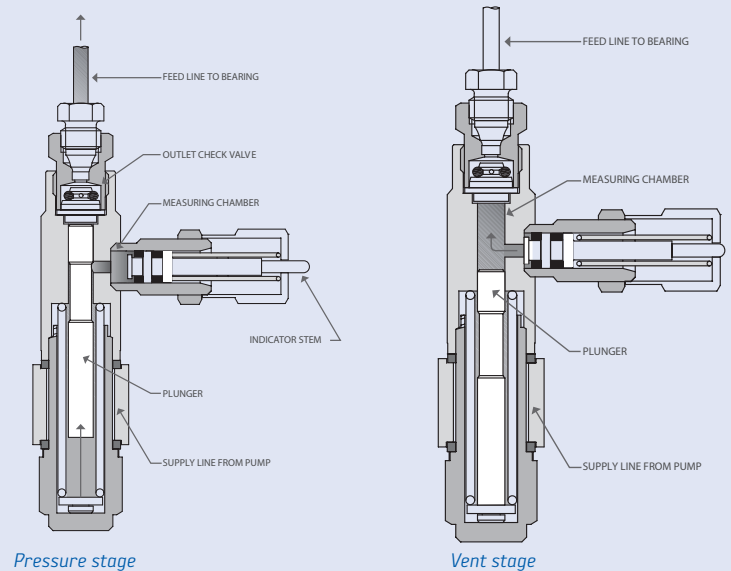

Adjusting ExactoServe Injector Discharge

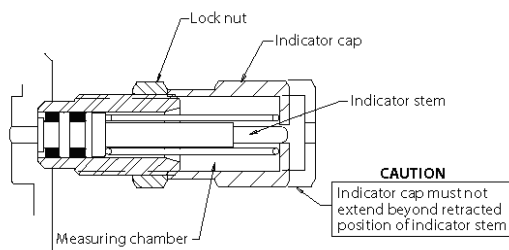

On all ExactoServe injectors, the amount of discharge is controlled by the position of the indicator cap.

To decrease injector output to the minimum discharge, hand tighten the indicator cap onto the measuring chamber.

To increase injector output to the maximum, loosen the indicator cap its full range – five turns for the FL-32 or FL-43; two turns for the FL-33 or FL-42.

When the indicator cap is adjusted to the desired position, tighten the adjacent locknut against its face.

Note¹: Loosening the indicator cap beyond the maximum will not increase output and may interfere with the operation of the indicator stem.

Note²: Always verify flow at minimum setting

Grease Injectors

Series FL-33

FL-33 injectors are positive displacement grease dispensing valves. They can be used in lube circuits with our FL-32/FL-1/FL-11 series injectors.

Features That Makes the Difference

- VITON O-rings standard to protect against high heat & synthetic lubricants
- Form, fit and functional interchangeable with major competitive brand
- All injectors are shipped with vinyl cover caps standard
- Operating pressures to 3,500 psi
- All manifolded injectors include outlet tube fittings and manifold mounting brackets & screws
- Available in standard or 304 Stainless Steel
- Adjustable grease output
- Visual operating indicator pin

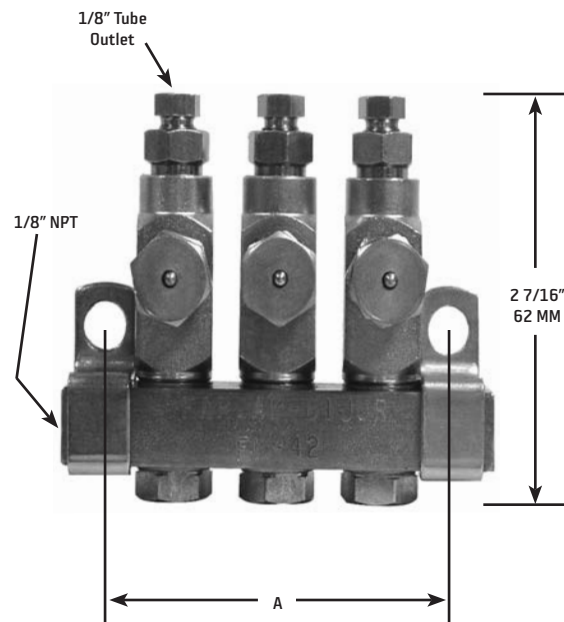

Ordering Information

Model		Number of Injectors	Dimensions	
Carbon Steel	Stainless Steel (304)		A	
			In.	MM
27164-1	27164-1SS	1	1 1/8	29
27164-2	27164-2SS	2	1 7/8	48
27164-3	27164-3SS	3	2 5/8	67
27164-4	27164-4SS	4	3 3/8	86
27164-5	27164-5SS	5	4 1/8	105
27164-6	27164-6SS	6	4 7/8	124
--	27164-7SS	7	5 5/8	143
27164-9	17164-9SS	9	7 1/8	181
27164-10	--	10	7 7/8	200
27164-15	27164-15SS	15	11 5/8	295
27164	27164-SS	1	Single Injector/Direct Mount	
27163-R	27164-RSS	1	Single Replacement Injector	

FL-33 Series Specifications

Operating Pressure	Maximum: 3500 psi (241 BAR) Minimum: 1200 psi (83 BAR)
Lube Output - Adjustable	.001 cu. in. (.016 cc) - .003 cu. in. (.049 cc)
Vent/Relief Pressure	200 psi (14 BAR) or less
Lubricants	Up to NLGI #2 grease
Seals	Viton O-rings (70 durometer)
Max. Temperature	350°F (176°C)
Material	Steel with zinc and yellow chromate plating or 304 stainless steel
Pipe Connections	Injector manifold inlet - 1/8" NPT Injector outlet - 1/8" O.D. tube

Refer to the following documents for more info:

+ *Datasheet #27317: FL-33 Injector*

Grease Injectors

Series FL-32

FL-32 injectors are positive displacement grease dispensing valves. They can be used in lube circuits with our FL-33/FL-1/FL-11 series injectors.

Features That Make the Difference

- VITON O-rings standard to protect against high heat & synthetic lubricants
- Form, fit and functional interchangeable with major competitive brand
- All injectors are shipped with vinyl cover caps standard
- Operating pressures to 3,500 psi
- All manifolded injectors include outlet tube fittings and manifold mounting brackets & screws
- Available in standard or 304 Stainless Steel
- Adjustable grease output
- Visual operating indicator pin

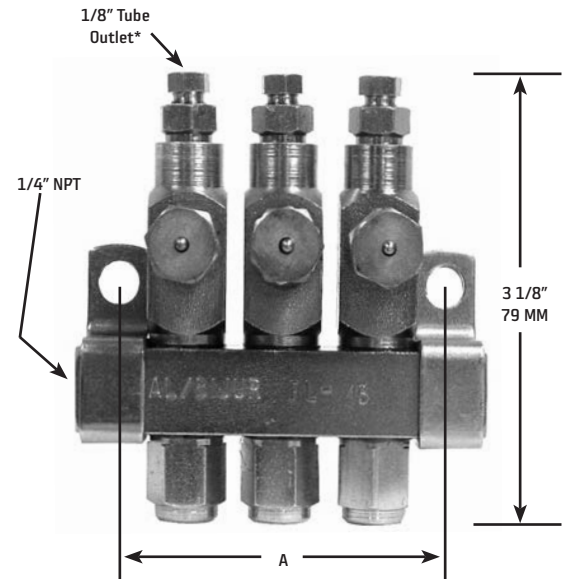

Ordering Information

Model		Number of Injectors	Dimensions	
Carbon Steel	Stainless Steel (304)		A	
			In.	MM
27163-1	27163-1SS	1	1 1/4	32
27163-2	27163-2SS	2	2	51
27163-3	27163-3SS	3	2 3/4	70
27163-4	27163-4SS	4	3 1/2	89
--	27163-10SS	10	8	203
27163	27163SS	1	Single Injector/Direct Mount	
27163-R	27163-RSS	1	Single Replacement Injector	
37997	--	1	Single Replacement Injector 1/8" NPT female outlet	

Refer to the following documents for more info:

+ Datasheet #27314: FL-32 Injector

FL-32 Series Specifications

Operating Pressure	Maximum: 3500 psi (241 BAR) Minimum: 1200 psi (83 BAR)
Lube Output - Adjustable	.001 cu. in. (.016 cc) - .008 cu. in. (.131 cc)
Vent/Relief Pressure	200 psi (14 BAR) or less
Lubricants	Up to NLGI #2 grease
Seals	Viton O-rings (70 durometer)
Max. Temperature	350°F (176°C)
Material	Steel with zinc and yellow chromate plating or 304 stainless steel
Pipe Connections	Injector manifold inlet - 1/4" NPT Injector outlet - 1/8" O.D. tube

*37997 has 1/8" NPT female threads

Grease Injectors

Series FL1

FL-1 injectors are positive displacement grease dispensing valves. They can be used in lube circuits with our FL-32/FL-33/FL-11 series injectors.

Features That Make the Difference

- VITON O-rings standard to protect against high heat & synthetic lubricants
- Form, fit and functional interchangeable with major competitive brand
- All injectors are shipped with vinyl cover caps standard
- Operating pressures to 3,500 psi
- Adjustable grease output
- Visual operating indicator pin
- Includes feed line fill fitting

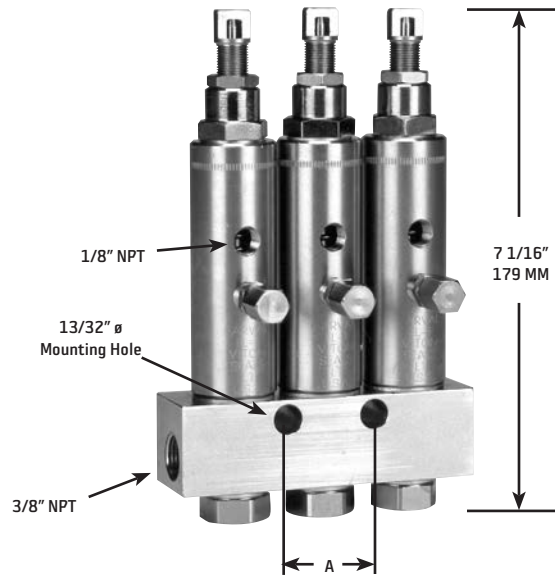

Ordering Information

Model		Number of Injectors	Dimensions	
Carbon Steel	Stainless Steel (304)		A	
			In.	MM
FL11	FL11-SS	1	Single Hole Mounting	
FL12	FL12-SS	2		
FL13	FL13-SS	3		
FL14	FL14-SS	4	2 1/2	63
FL15	FL15-SS	5	3 3/4	95
FL16	FL16-SS	6	5	127
13844	--	1	Single Injector/No Manifold (3/8" NPTF (M) inlet)	
13843	13843-SS	1	Replacement for manifold injector	

FL 1 Series Specifications

Operating Pressure	Maximum: 3500 psi (241 BAR) Minimum: 1850 psi (127 BAR)
Lube Output - Adjustable	.008 cu. in. (.131 cc) - .100 cu. in. (1.64 cc)
Vent/Relief Pressure	600 psi (41 BAR) or less
Lubricants	Up to NLGI #2 grease
Seals	Viton O-rings (70 durometer)
Max. Temperature	350°F (176°C)
Material	Steel with zinc and yellow chromate plating or 316 stainless steel
Pipe Connections	Injector manifold inlet - 3/8" NPT Injector outlet - 1/8" NPT

Refer to the following documents for more info:

+ *Datasheet #34254: FL1 Injector*

Grease Injectors

Series FL-11

FL-11 injectors are positive displacement grease dispensing valves. They can be used in lube circuits with our FL-32/FL-33/FL-1 series injectors.

Features That Make the Difference

- VITON O-rings standard to protect against high heat & synthetic lubricants
- Form, fit and functional interchangeable with major competitive brand
- All injectors are shipped with vinyl cover caps standard
- Operating pressures to 3,500 psi
- Adjustable grease output
- Visual operating indicator pin
- Includes feed line fill fitting

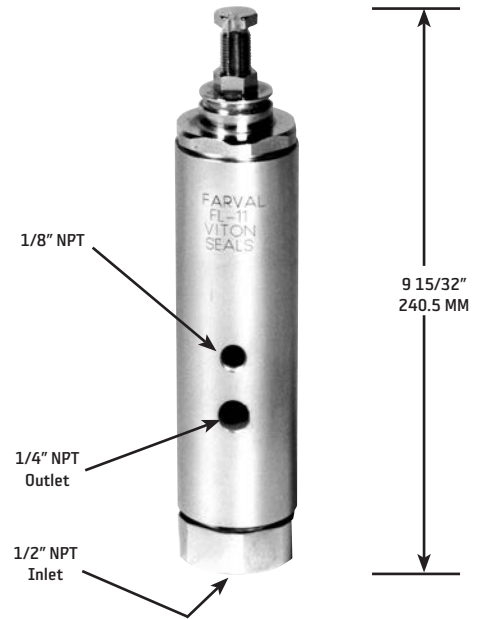

Ordering Information

Model
Carbon Steel
FL-11

Refer to the following documents for more info:

+ [Datasheet #34255: FL-11 Injector](#)

FL-11 Series Specifications

Operating Pressure	Maximum: 3500 psi (241 BAR) Minimum: 1000 psi (69 BAR)
Lube Output - Adjustable	.050 cu. in. (.82 cc) - .500 cu. in. (.8.2 cc)
Vent/Relief Pressure	800 psi (55 BAR) or less
Lubricants	Up to NLGI #2 grease
Seals	Viton O-rings (70 durometer) & hytrel packings
Max. Temperature	200°F (93°C)
Material	Steel with zinc and yellow chromate plating
Pipe Connections	Injector inlet - 1/2" NPT Injector outlet - 1/4" NPT

Oil Injectors

Series FL-42

FL-42 injectors are positive displacement oil dispensing valves. They can be used in lube circuits with our FL-43/FL-44/FL-45 series injectors.

Features That Make the Difference

- VITON O-rings standard to protect against high heat & synthetic lubricants
- Form, fit and functional interchangeable with major competitive brand
- All injectors are shipped with vinyl cover caps standard
- Operating pressures to 1,000 psi
- All manifolded injectors include outlet tube fittings & manifold mounting brackets & screws
- Adjustable oil output
- Visual operating indicator pin

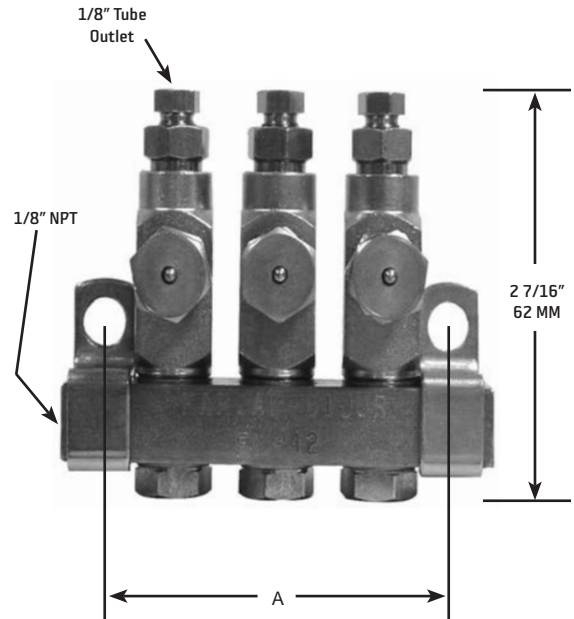

Ordering Information

Model		Number of Injectors	Dimensions	
Standard Heat Resistant	Stainless Steel (316)		A	
			In.	MM
27165-1	27165-1SS	1	1 1/8	29
27165-2	27165-2SS	2	1 7/8	48
27165-3	27165-3SS	3	2 5/8	67
27165-4	27165-4SS	4	3 3/8	86
27165-5	27165-5SS	5	4 1/8	124
27165-6	27165-6SS	6	4 7/8	124
--	27165-10SS	10	7 7/8	200
27165-15	27165-15SS	15	11 5/8	295
27165-R	27165-RSS	1	Single Replacement Injector	
27165	27165SS	1	Single Injector/Direct Mount	

FL-42 Series Specifications

Operating Pressure	Maximum: 1000 psi (69 BAR) Minimum: 750 psi (52 BAR)
Lube Output - Adjustable	.001 cu. in. (.016 cc) - .003 cu. in. (.049 cc)
Vent/Relief Pressure	150 psi (10 BAR) or less
Lubricants	Oil - semi fluid grease
Seals	Viton O-rings (70 durometer)
Max. Temperature	350°F (176°C)
Material	Steel with zinc and yellow chromate plating or 316 stainless steel
Pipe Connections	Injector manifold inlet - 1/8" NPT Injector outlet - 1/8" O.D. tube

Refer to the following documents for more info:

+ *Datasheet #27311: FL-42 Injector*

Oil Injectors

Series FL-43

FL-43 injectors are positive displacement oil dispensing valves. They can be used in lube circuits with our FL-42/FL-44/FL-45 series injectors.

Features That Make the Difference

- VITON O-rings standard to protect against high heat & synthetic lubricants
- Form, fit and functional interchangeable with major competitive brand
- All injectors are shipped with vinyl cover caps standard
- Operating pressures to 1,000 psi
- All manifolded injectors include outlet tube fittings & manifold mounting brackets & screws
- Adjustable oil output
- Visual operating indicator pin

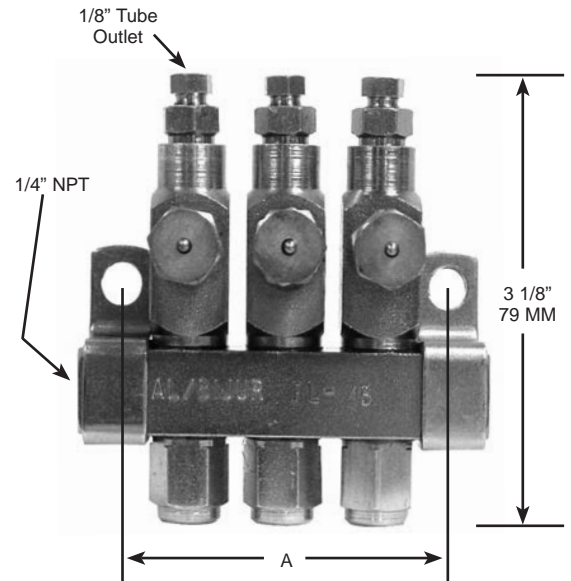

Ordering Information

Model		Number of Injectors	Dimensions	
Standard Heat Resistant	Stainless Steel (316)		A	
			In.	MM
27166-1	27166-1SS	1	1 1/4	32
27166-2	27166-2SS	2	2	51
27166-3	27166-3SS	3	2 3/4	70
27166-4	27166-4SS	4	3 1/2	89
27166	27166SS	1	Replacement for Manifolded Injector	
27166-R	27166-RSS	1	Single Injector/Direct Mount	

FL-43 Series Specifications

Operating Pressure	Maximum: 1000 psi (69 BAR) Minimum: 750 psi (52 BAR)
Lube Output - Adjustable	.001 cu. in. (.016 cc) - .008 cu. in. (.131 cc)
Vent/Relief Pressure	150 psi (10 BAR) or less
Lubricants	Oil - semi fluid grease
Seals	Viton O-rings (70 durometer)
Max. Temperature	350°F (176°C)
Material	Steel with zinc and yellow chromate plating or 316 stainless steel
Pipe Connections	Injector manifold inlet - 1/4" NPT Injector outlet - 1/8" O.D. tube

Refer to the following documents for more info:

+ Datasheet #27313: FL-43 Injector

Oil Injectors

Series FL-44

FL-44 injectors are positive displacement oil dispensing valves. They can be used in lube circuits with our FL-42/FL-43/FL-45 series injectors.

Features That Make the Difference

- VITON O-rings standard to protect against high heat & synthetic lubricants
- Form, fit and functional interchangeable with major competitive brand
- All injectors are shipped with vinyl cover caps standard
- Operating pressures to 1,000 psi
- Adjustable oil output
- Visual operating indicator pin
- Includes feed line fill fitting

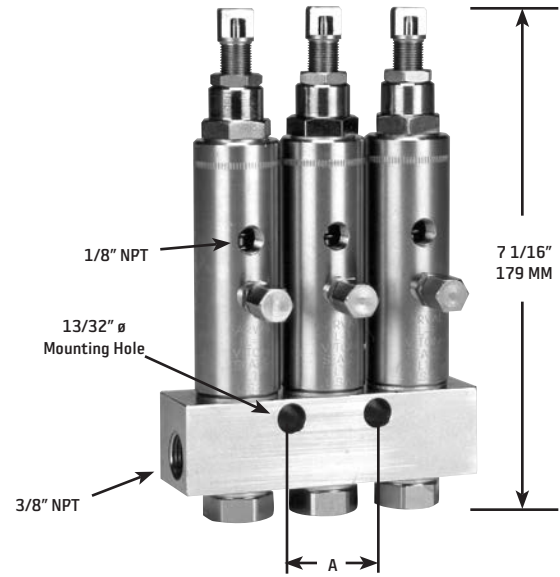

Ordering Information

Model	Number of Injectors	Dimensions	
		A	
Carbon Steel		In.	MM
FL44-1	1	Single Hole Mounting	
FL44-2	2		
FL44-3	3	1 1/4	32
FL44-4	4	2 1/2	63
FL44-5	5	3 3/4	95
FL44-6	6	2 1/2	63
FL44	1	Replacement for Manifolded Injector	
FL44-DM	1	Single Injector/Direct Mount	

FL-44 Series Specifications

Operating Pressure	Maximum: 1000 psi (69 BAR) Minimum: 750 psi (52 BAR)
Lube Output - Adjustable	.008 cu. in. (.031 cc) - .100 cu. in. (1.64 cc)
Vent/Relief Pressure	150 psi (10 BAR) or less
Lubricants	Oil - semi fluid grease
Seals	Viton O-rings (70 durometer)
Max. Temperature	350°F (176°C)
Material	Steel with zinc and yellow chromate plating
Pipe Connections	Injector manifold inlet - 3/8" NPT Injector outlet - 1/8" NPT

Refer to the following documents for more info:

+ *Datasheet #32725: FL-44 Injector*

Oil Injectors

Series FL-45

FL-45 injectors are positive displacement oil dispensing valves. They can be used in lube circuits with our FL-42/FL-43/FL-44 series injectors.

Features That Make the Difference

- VITON O-rings standard to protect against high heat & synthetic lubricants
- All injectors are shipped with vinyl cover caps standard
- Operating pressures to 1,000 psi
- Adjustable oil output
- Visual operating indicator pin
- Includes feed line fill fitting

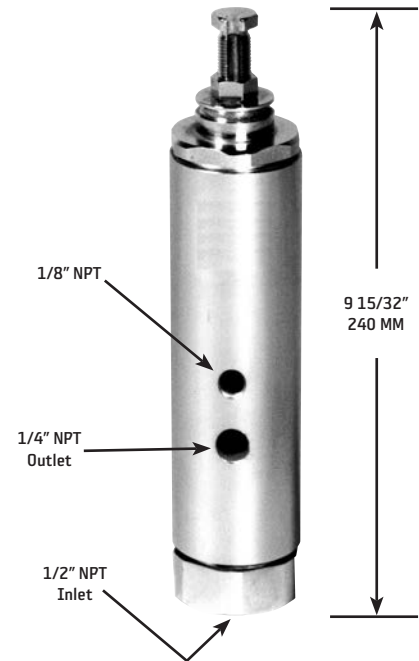

Ordering Information

Model
Carbon Steel
FL-45

FL-45 Series Specifications

Operating Pressure	Maximum: 1000 psi (69 BAR) Minimum: 750 psi (52 BAR)
Lube Output - Adjustable	.050 cu. in. (.82 cc) - .500 cu. in. (.8.2 cc)
Vent/Relief Pressure	150 psi (10 BAR) or less
Lubricants	Oil - semi fluid grease
Seals	Viton O-rings (70 durometer) & hytrel packings
Max. Temperature	200°F (93°C)
Material	Steel with zinc and yellow chromate plating
Pipe Connections	Injector inlet - 1/2" NPT Injector outlet - 1/4" NPT

Refer to the following documents for more info:

+ *Datasheet #32698: FL-45 Injector*

Injector Accessories



Pipe Plugs for Injectors / Manifolds

Used to plug lube outlets of injectors / manifolds

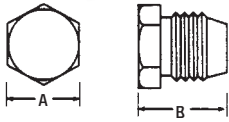

Type 1

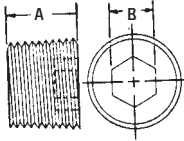

Type 2

Ordering Information

Model	Thread Type (in.)	A (in.)	B (in.)	Type
27336 ¹ (Steel)	5/16-24	5/16	1/2	1
27336SS ¹ (Stainless Steel)				
U119AC (Steel)	1/8 NPT	5/16	3/16	2
UST119AC (Stainless Steel)				
U119CC (Steel)	3/8 NPT	1/2	5/16	2
U119BC (Steel)				
UST119BC (Stainless Steel)	1/4 NPT	7/16	1/4	2

Note¹: For plugging outlet of series FL-32, 33, 42, 43 injectors.



Compression Nuts for Injector Outlets

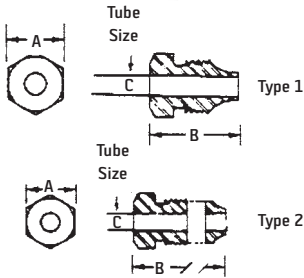

Type 1

Type 2

Model	Thread Type (in.)	A (in./mm.)	B (in./mm.)	C (Tube O.D.)	Type
27337 (Brass)	5/16-24	5/16 / 7.9	1/2 / 12/7	1/8	1
27340 (Brass)					2
27340SS (Stainless Steel)					2
27341 ¹ (Brass)	7/16-24	7/16 / 11.1	5/8 / 15.9	1/4	1

Note¹: Use with 27349 Adapter - page 14.

Vent Valve Part No. 13850

Vent Valve is used with injectors to relieve system pressure back to reservoir after a lubrication cycle. With a pneumatic operated drum pump, air pressure would be applied to the vent valve at the same time as the pump. When air pressure is relieved from pump and vent valve, lubricant moves past the valve seat and out vent port, and piped back to the drum.

Specifications

Max. Air Pressure	120 psi (8 bar)
Min. Air Pressure	40 psi (3 bar)
Max. Lubricant Pressure	3800 psi (262 bar)
Mounting	Any position
Recommended Lubricants	Oil to NLGI No. 2 grease

Refer to the following documents for more info:

- + Datasheet #35976: Vent Valve
- + Datasheet #32238: Vent Valve Kit

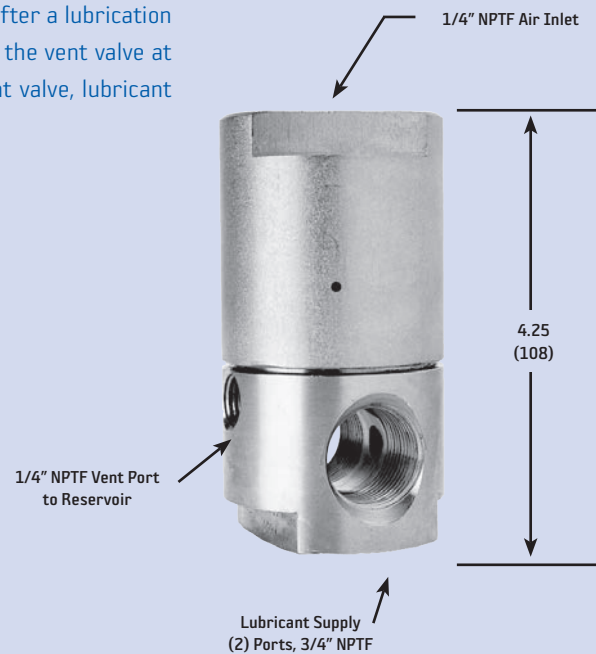

Note: Also available as an assembly with air, and lube hoses and fittings. Order Part #32087.

Injector Accessories



Injector Outlet Adapter

For use with FL-32, FL-33, FL-42 and FL-43 Injectors.

Part No. 27348, 1/8" NPT Female

Part No. 27349, 1/4" O.D. Tube (Use with 27341 - pg. 13)

Part No. 27351, 1/8" NPT Male

Part No. 37256, 6mm O.D. Tube Adapter

Part No. 27167-1, 4mm O.D. Tube(5/32") (Use with B3783 & B8272 or B1061)

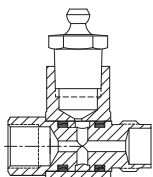

Manual Lubrication Adapter

Allows pre-filling of feed lines and manual lubrication of the machine.

For use with FL-32, FL-33, FL-42 and FL-43 injectors.

Part No. 37035 has 1/8 NPT Female Connection



FL Manifold Plug Kit

Allows plugging of ports on FL1 & FL44 manifolds.

Part No. 37233

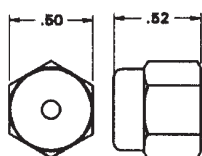

Injector Locking Cap

Disables the injector adjustment feature. Locking cap sets injector output.

Part Number	Injector Series	Fixed Volume Output
27347	FL-32, 43	.002 in. ³ /.033 cc
	FL-33, 42	.003 in. ³ /.049 cc



Injector Connector Tube

Combines discharge of two or more injectors through one feed line. It is used when a bearing lube requirement cannot be met from one injectors output.

Model	For Injector Series	Connections
13899	FL-1, 44	1/8" NPTF Male

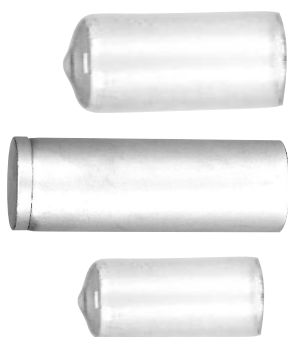

Injector Cover Caps

Injector cover caps protect the injector from dirt, and other harmful contaminants.

Model	For Injector Series	Application	Material	Length	
				In.	MM.
U1732D	FL-1, FL44	Indicator Stem	Vinyl	1.5	38.1
U1732E	FL11/FL-45			2.0	50.8
27335	FL32, FL33, FL42, FL43	Measuring Chamber	Aluminum	1.25	31.2
CAP13896A	FL-1, 44	Injector Body		3.25	82.6

Injector Accessories

Operation

Brush Assemblies are suitable for lubricating various moving machine components such as: chains, gears, cams, etc. Oil flow to each brush may be governed by a FL-42, 43, 45, or 44 series injector.

Technical Data

Bristle Material	.012" diameter black nylon
Temperature Range	-30°F to +200°F

Installation

Bristle end of brush must be below inlet connection. Mount securely to avoid vibration.

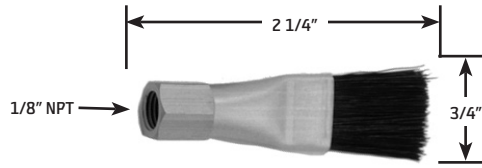

Brush Assembly, Part No. B7488

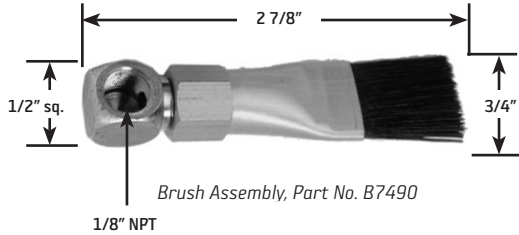

Brush Assembly, Part No. B7490

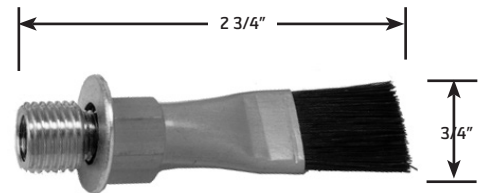

Bulkhead Mounted Brush Assembly	Part Number
1/8" Pipe Tap (Female) 9/16" - 18 Male Thread	B7492

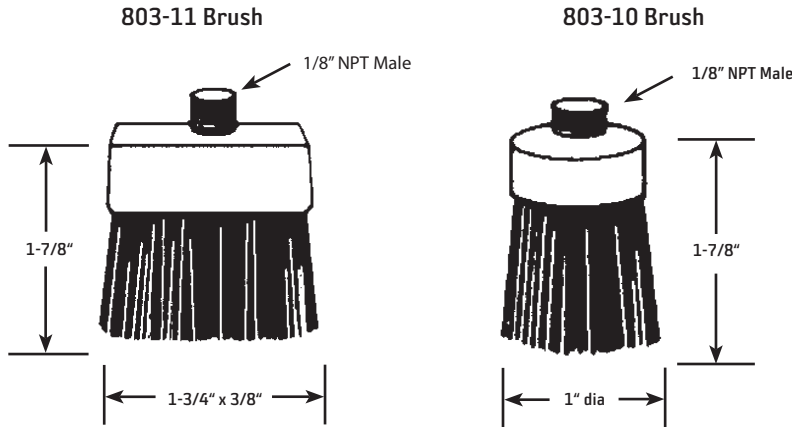

U922C Spray Nozzle Assemblies

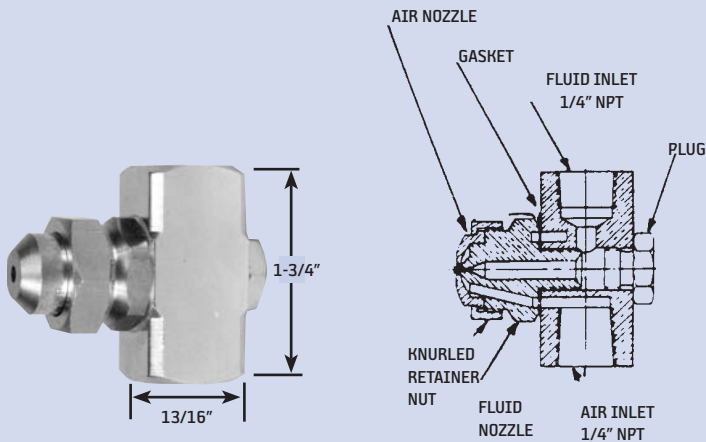

Maximum Working Pressure - 500 psi

U987 Spray Nozzle Adapter (For Wall Mounting U922C)

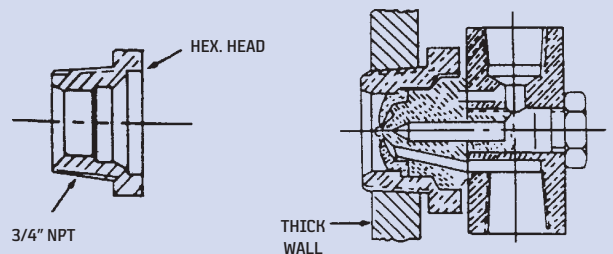

Replace retainer nut of U922C with adapter. Adapter threads directly into wall.

Manual Grease Pumps

25057-1 Economy Grease Pump

Manual actuated piston pump with a built-in pressure relief valve. Unit can be used in conjunction with FL-32, -33, injectors. Pump is equipped with a grease follower plate and can discharge soft greases. All models have 'see through' plastic reservoirs.

Model	25057-1
Discharge Per Cycle	.060 cu. in. (1.0 cc)
Reservoir Capacity	2 lb. (1 kg)
Lube Outlet	1/8" NPTF (F)
Operating Pressure	Max. 2175 psig (150 bar)
Dimensions (H x W x L)	13.5" x 5.5" x 6.6" (343 x 140 x 167 mm)
Filling Method	Bulk Fill



Refer to the following documents for more info:
+ *Datasheet #27402: Manual Injector Lubricator*

DA4101AC Grease Pump

Manual actuated piston pump with a built-in pressure relief valve. Unit can be used in conjunction with FL-32, -33, -1 injectors. Pump is equipped with a grease follower plate and can discharge up to NLGI #2 grease.

Model	DA4101AC
Discharge Per Cycle	.45 cu. in. (7.4 cc)
Reservoir Capacity	4-1/2 lb. (2 kg)
Lube Outlet	1/4" NPTF (F)
Operating Pressure	Max. 3500 psig (241 bar)
Dimensions (H x W x L)	24" x 9-1/8" x 7-3/4" (609 x 228 x 197 mm)
Filling Method	Filler Pump



Refer to the following documents for more info:
+ *Datasheet #35495: DA Lubricator*

Air-Operated (Single Stroke) Grease Pumps

General

The SureMatic Lubricator comprises a piston discharge pump actuated by air, controlled by an electric solenoid 3-way valve. Models are available to handle grease to NLGI #2. Low level switch is standard.

Application

Unit discharges lubricant on single action air powered forward stroke and actuates all positive displacement injectors connected to the single line centralized distribution network. A two directional outlet check valve vents pressure back to reservoir on spring powered return stroke.

Lubricator can be used with the following injectors:

- Series FL-32, 33 Injectors

Features

Reservoirs	Four sizes are available
Follower Plate	Weighted (no spring necessary)
Low Level Switch	Follower plate actuates built-in switch contacts



Specifications

Model	Ratio	Pump Output	Reservoir Capacity (KG)	Air Inlet	Lube Outlet	Lubricant Oper. Press. Max.	Dimensions H x W x L (MM)
18143C	18:1	.46 in. ³ 7.6 cm ³	2 LB (1 KG)	1/4" NPTF (F)	1/4" NPTF (F)	2700 psi ¹ (186 BAR) ¹	11" x 6-3/8 x 10" (280 x 162 x 254)
18140C			4 LB (2 KG)				14" x 6-3/8 x 10" (356 x 162 x 254)
18141C			7 LB (3.2 KG)				18" x 6-3/8 x 10" (457 x 162 x 254)
18142C			10 LB (4.6 KG)				23" x 6-3/8 x 10" (584 x 162 x 254)

Note¹: Max lube pressure at 150 psi air pressure (10 bar.)

Note²: See page 25 for timers.

Refer to the following documents for more info:

+ Datasheet #35484: Surematic Lubricator

Air-Operated (Reciprocating) Grease Pumps

General

Air operated reciprocating grease discharge pump assembly, complete with vent valve. Pump is used with ExactoServe grease injectors. During operation, incoming air flowing to pump air inlet builds up system pressure to discharge all injectors connected to the network. Pump cycle frequency is normally controlled by pressure switch in main supply line to indicate when operating pressure is attained. Models are available with low level switches. A grease quick fill connection is located at base of reservoir.

Technical Data

Reservoir Capacity	2.5 and 5 liter (5 and 10 lb.)
Grease Lubricant Range	NLGI grade 000-2
Pressure Ratio	30:1
Output/Min at 100 psi air	90cc (5.5 cu. in.)
Air Consumption at 100 psi	0.1 m ³ /min. or 3.5 cubic feet per min. (approximately 104 piston strokes per min.)
Air Inlet	1/8" NPTF (F)
Lube Outlet	1/4" NPTF (F)
Air Supply Pressure Range	40-100 psi (3-7 bar)
Reservoir Material	Translucent acrylic and steel

Note: Lubricator requires a 3-way solenoid air valve.

How to Order

Reservoir Size/Type	Part Number
2.5 L (5 lb.) Steel with LLS	32005-2
2.5 L (5 lb.) Plastic with LLS	32005-4
5 L (10 lb.) Plastic with LLS	32005-8

Dimensions	2.5 L Steel LLS	2.5 L Plastic LLS	5.0 L Plastic LLS
A	395	395	573
B	623	623	801

Refer to the following documents for more info:

+ Datasheet #35691: SKA881 Lubricator

Note: See page 25-27 for timers and controllers

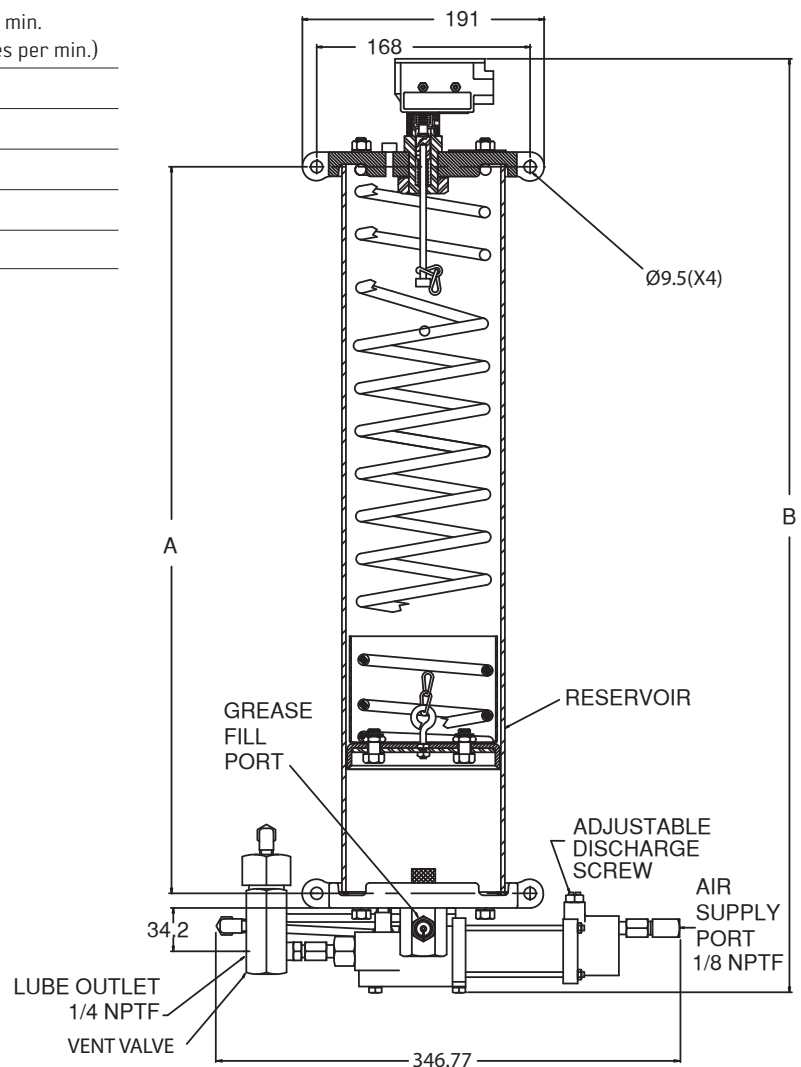

Air-Operated Grease Drum Pump Packages

Model 14550

Consists of drum pump, vent valve assembly, with lube and air hoses, drum cover, and control panel.

Model	14550	
Lubricant/Air Ratio	55:1	
Output/Min. at 100 psig air	40 cu. in. (656 cc)	
Drum Size	120 lb. drum	
Air Inlet	3/8" NPTF (F)	
Lube Outlet	3/4" NPTF (F)	
Typical System	Min. 1200 psig (82 BAR)	
Operating Pressure	Max. 3500 psig (241 BAR)	
Components Included	Pump	9120
	Controller	32088 (See page 27)
	Vent Valve	32087 (See page 13)

Note: Model F964 follower plate is available to order separate.



Model 14550

Model 9035

Consists of 55:1 std. duty pump for 35 lb. pail. Includes drum cover, follower plate, and lube return hose. (Order vent valve separately. See page 13.)

Model 14552 Heavy Duty Unit

Consists of 6" HD pump, vent valve with air and lube hoses, drum cover, follower plate and control panel.

Model	14552	
Lubricant/Air Ratio	55:1	
Output/Min. at 100 psig air	348 cu. in. (5704 cc)	
Drum Size	400 lb. drum	
Air Inlet	3/8" NPTF (F)	
Lube Outlet	3/4" NPTF (F)	
Typical System	Min. 1200 psig (82 BAR)	
Operating Pressure	Max. 3500 psig (241 BAR)	
Components Included	Basic Pump	F624
	Vent Valve Assy	32087 (See page 13)
	Controller	32088 (See page 27)
	Drum Cover	37013
	Follower Plate	37014
	Relief Hose Kit	37019



Model 14552



Model 32088

Refer to the following documents for more info:
+ Datasheet #35993: DP55 Pumps

Electric Grease Drum Pumps

Description

Bijur Delimon's AC or DC electric barrel pumps will replace the air or hydraulic operated pumps now used for lube systems on mobile or stationary equipment. Installation is cleaner - no air or hydraulic lines to install/leak. Simply wire into the machines 12, 24, or 110-volt supply. Pressure rated to 4000 psi. Will fit original refinery 35 and 120 lb. drums.

All models include vent valve, pressure switch, drum cover, and follower plate.

Operation

12/24 VDC Pumps

The pump end (bottom) consists of a hardened steel bushing, through which the piston runs. As the piston strokes down, grease is pushed past the check valve ball and out through the extruded discharge holes in the pump stem. As the piston strokes up, the check valve prevents drawback, and a vacuum is created inside the bushing. When the piston uncovers the suction holes in the bushing, another charge of grease is drawn in through the suction ports on the bottom of the stem and into the bushing. The cycle then repeats.

115 VAC Pumps

The 115 VAC Pumps use a 1/4 hp., open drip-proof gearmotor, with a cam and roller follower to actuate the pump plunger. Bottom-end (pump) is identical to the DC units.

Electric Barrel Pump Specifications

Model Number	Voltage AC/DC	Container Size	Pressure Max psi	Lube Flow Output/Min.	Amp Draw Normal	Amp Draw Spike
FEP312V	12 VDC	35 lb. pail	4000	14.5 cu. in.	See Note ¹	80 amps
FEP322V	12 VDC	120 lb. drum		14.5 cu. in.	See Note ¹	80 amps
FEP712V	24 VDC	35 lb. pail		12 cu. in.	See Note ²	40 amps
FEP722V	24 VDC	120 lb. drum		12 cu. in.	See Note ²	40 amps
FEP812V	115 VAC 50/60 Hz	35 lb. pail		11 cu. in.	See Note ³	5 amps
FEP822V	115 VAC 50/60 Hz	120 lb. drum		11 cu. in.	See Note ³	5 amps

Note¹: 12 VDC 15-20 amp draw at free flow. 30-40 amp draw at 3000 psi

Note²: 24 VDC 10 amp draw at free flow. 15-20 amp draw at 3000 psi

Note³: 115 VAC amp draw at free flow or 3000 psi

Note⁴: Lube Outlet port is 1/4" NPT (F)



120 lb. (110 volt)



35 lb. (12/24-volt)

Note: Lube containers supplied by others.

Dimensions for AC/DC Pumps

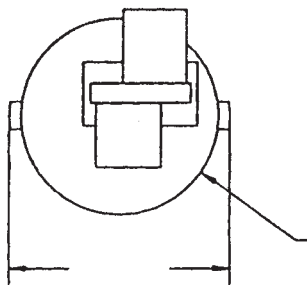

	35 lb. Pail	120 lb. Drum
A	13"	25 1/2"
B	14 5/8"	17 1/2"
C	12 1/2"	15 1/4"

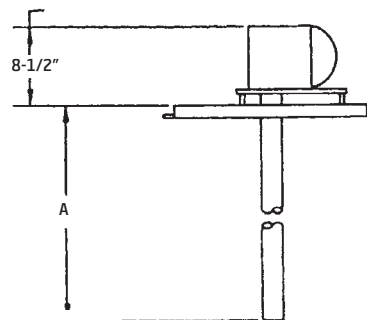

Drum Heater Insulated Blankets 120 VAC

- Model 37506 Fits 120lb Drum (15 gal/57 liter)
- Model 55286 Fits 400lb Drum (55 gal/208 liter)



Refer to the following documents for more info:

+ Datasheet #35975: Electric Drum Pumps

+ Datasheet # 35745: Drum Heater Blankets

Air-Operated (Single Stroke) Oil Pumps

General

The SureMatic Lubricator comprises a piston discharge pump actuated by air, controlled by an electric solenoid valve. Models can handle oil to 8,000SSU.

Application

Unit discharges lubricant on single action air powered forward stroke and actuates all positive displacement injectors connected to the single line centralized distribution network. A two directional outlet check valve vents pressure back to reservoir on spring powered return stroke.

Lubricator can be used with the following injectors:

- Series FL-42, 43

Features

- Reservoirs are available in four sizes.
- Low level switch is standard on all models.
- Air solenoid (3 way) and on-off timer combos are available.



Specifications

Model	Ratio	Pump Output	Reservoir Capacity (Liters)	Air Inlet	Lube Outlet	Lubricant Oper. Press. Max.	Dimensions H x W x L (MM)
18144C	18:1	.46 in. ³ 7.6 cm ³	2 pints (1 LT)	1/4" NPTF (F)	1/4" NPTF (F)	2700 psi ¹ (186 BAR) ¹	11" x 6-3/8 x 10" (280 x 162 x 254)
18145C			4 pint (2 LT)				14" x 6-3/8 x 10" (356 x 162 x 254)
18146C			7 pints (3.2 LT)				18" x 6-3/8 x 10" (457 x 162 x 254)
18147C			10 pints (4.6 LT)				23" x 6-3/8 x 10" (584 x 162 x 254)

Note¹: Max lube pressure at 150 psi air pressure (10 bar.)

Note²: See page 25 for timers.

Refer to the following documents for more info:

+ Datasheet #35484: Surematic Lubricator

Air-Operated (Reciprocating) Oil Pumps

General

Air operated reciprocating oil discharge pump assembly, complete with vent valve. Pump is used with ExactoServe injectors. During operation, incoming air flowing to pump air inlet builds up system pressure to discharge all injectors connected to the network. Pump cycle frequency is normally controlled by pressure switch in main supply line to indicate when operating pressure is attained. Models are available with or without low level switches.

Technical Data

Reservoir Capacity	1.75 - 5.5 liter (2-6 qt.)
Oil Lubricant Range	ISO-8000 SSU (32-1700 cSt)
Pressure Ratio	30:1
Output/Min at 100 psi air	90cc (5.5 cu. in.)
Air Consumption at 100 psi	0.1 m ³ /min. or 3.5 cubic feet per min. (approximately 104 piston strokes per min.)
Air Inlet	1/8" NPTF (F)
Lube Outlet	1/4" NPTF (F)
Air Supply Pressure Range	40-100 psi (3-7 bar)
Reservoir Material	Translucent acrylic

Note: Lubricator requires a 3-way solenoid air valve.

How to Order

Reservoir Size/Type	Part Number
2.25 L (2.5 qt.)	32069-15
1.75 L (2 qt.) with LLS	32069-16
5.5 L (6 qt.)	32069-7
5.0 L (5.5 qt.) with LLS	32069-8

Refer to the following documents for more info:

+ Datasheet #35691: SKA881 Lubricator

Note: See page 25-27 for timers and controllers.

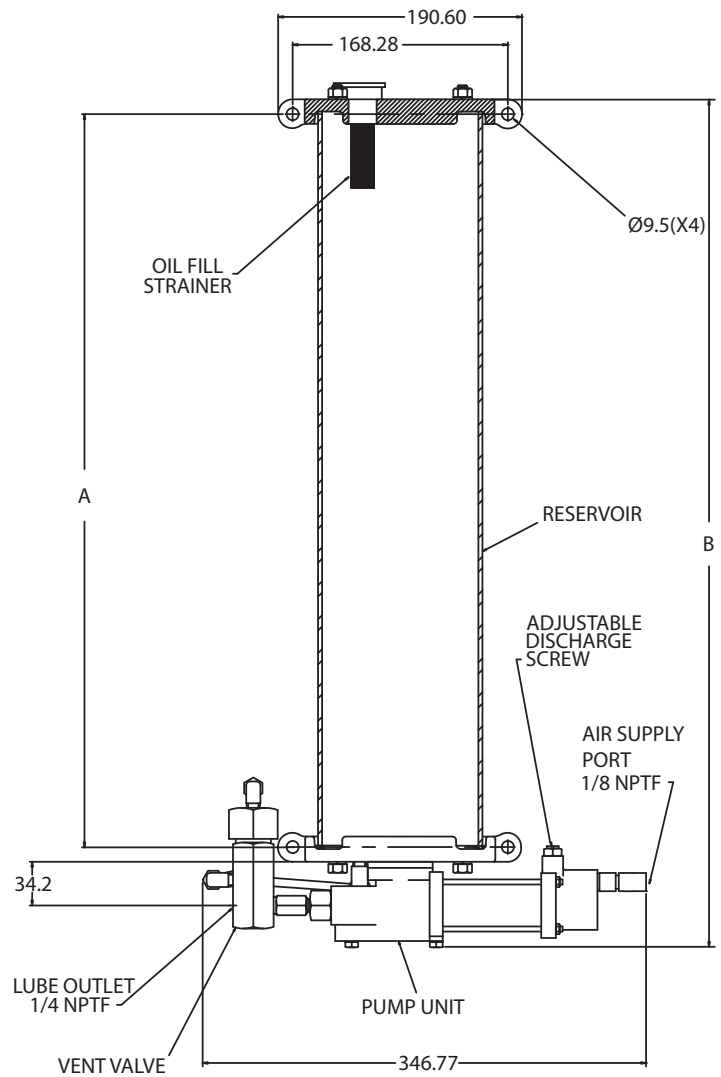

Dimensions	1.75 L	2.25 L	5.0 L	5.5 L
A	232	232	573	573
B	460	396	801	737

Electric Oil Pumps

General

The GPO Lubricator is a motor-driven gear pump that is designed for use with single line centralized lubricating systems utilizing progressive distributors or injectors. Standard features include: liquid level indicator, pressure gauge and strainer filler cap. An adjustable pressure regulating oil bypass valve is standard on Progressive systems and a dump valve is standard on Positive Displacement Injector (PDI) systems. Programmable controllers are available to operate the lubricator.

Technical Data

Maximum Discharge Pressure	1000 psi (69 bar)
Operating Temperature Range	40°F to 105°F (5°C to 40°C)
Reservoir Capacities	6 liter, 12 liter, 30 liter
Discharge	275cc/min (Single Phase) 500cc/min (Three Phase)
Output Connection	1/4" NPT (left and right options)
Oil Viscosity	20-1500 cSt



Refer to the following documents for more info:
+ Datasheet #35641: GPO Lubricator

How to Order

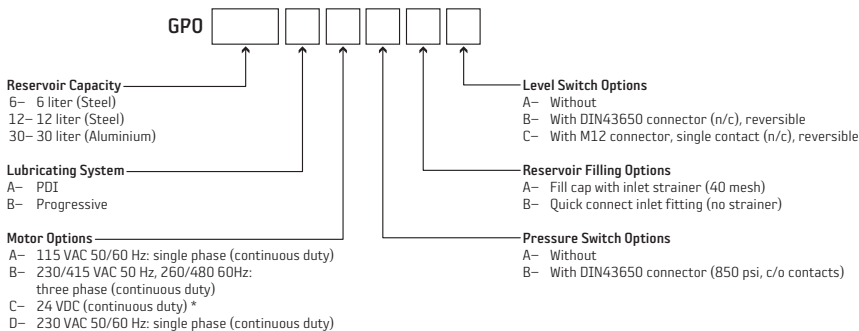

Dimensions

DIM	6 liter	12 liter	30 liter
A	360mm	318mm	468mm
B	215mm	260mm	340mm
C	229mm	370mm	490mm
D	200mm	156mm	291mm

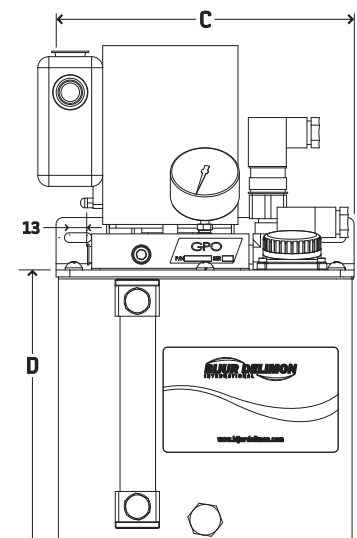
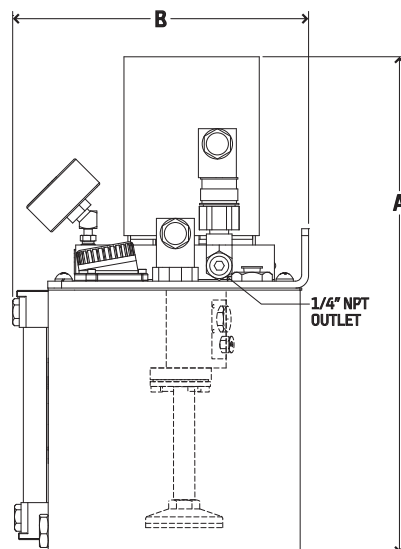

Electric Grease Pumps

General

The MultiPort Lubricator is an electrically driven multiple outlet lubrication unit design primarily for use with injector systems. The unit includes two pumping elements for a distribution network of injectors. These lubricators are available in 115 VAC or 24 VDC versions which make them ideal for use in industrial applications. Use of a remote timer/controller (SMAC/SMDC) or customer PLC is required for this lubricator.

Technical Data

Maximum Working Pressure	3000 psi (207 bar)	
Operating Temperature Range	5°F to 122°F (-15°C to 50°C)	
Reservoir Capacities	6 liter, 12 liter, 30 liter	
Output/Min	115VAC	10cc (0.61 cu. in.)
	24VDC	12cc (0.73 cu. in.)
Output Connection	1/4" NPTF	
Grease	NLGI grade 000-2	
Motor Enclosure	IP-55	
Motor Amperage	115 VAC	1.83 FLA
	24 VDC	2 FLA



Refer to the following documents for more info:
+ Datasheet #35954: Multiport INJ Lubricator

How to Order

Part Number	Reservoir	Voltage
37742	4 liter (8 lb)	115 VAC
37847	8 liter (16 lb)	115 VAC
37962	2 liter (4 lb)	24 VDC
37741	4 liter (8 lb)	24 VDC

Dimensions

	Reservoir Size	H1	H2
115 VAC	4 L	343	475
	8 L	545	674
24 VDC	2 L	245	376
	4 L	343	477

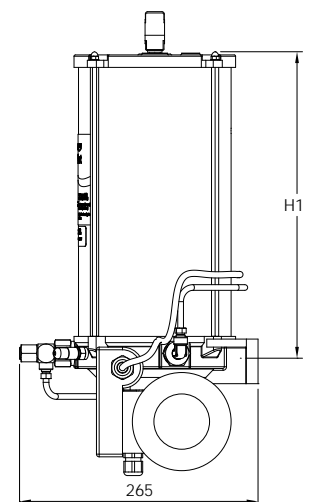
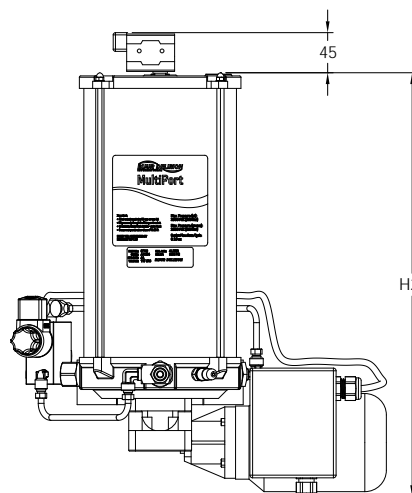
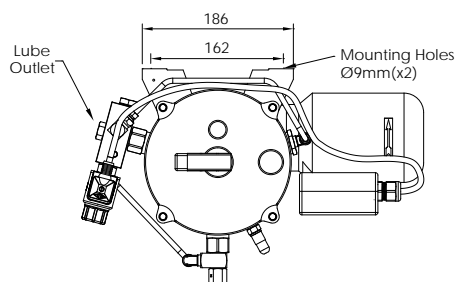

System Controllers

Timer for Pneumatic Operated Pumps Timer - Part No. 24476

General

A compact timer which mounts directly to a solenoid valve having DIN 43650 Form A electrical terminations.

Unit has four operating modes, with eight time ranges. Final time range settings are adjusted by potentiometers.

Two red light emitting diodes indicate power 'ON' and output energized (solenoid 'ON').

Technical Data

Supply Voltage	110-230V, 50/60 Hz, 710%
Power Consumption	1.0W maximum
Switching Load	1max = 0.5 A at supply voltage 110/230V, 50/60 Hz
Classification	IP 65, air gases and leakage paths according to VDE 0100
Body Material	Polyamide plastic
Working Temp. Range	32°-130°F (0°-55°C)
Indicator	LED connected power supply LED energized load
Adjustment	Basic function & time range via DIP switch settings Precision time adjustment via protentiometer
Time Range	Adjustable from .5 seconds to 10 hours



Timer mounted on 20311-3 Solenoid Valve (order separately)

Controller

The SS2200 is a microprocessor-based programmable controller designed to operate any central lubrication system. The SS2200 is housed in a NEMA 4X polycarbonate enclosure with a transparent cover. Visible through the cover are LED indicators for Idle, Lube and Fault modes, and a three-digit numerical display used for programming and monitoring lube system operation.

- Simple three key programming
- Controls both single line and dualine lubrication systems
- Operates electric or air driven pumps
- Time or machine cycle based operation
- Programmable for remote fault indication and emergency machine shutdown
- LED indicators and numerical displays monitor system operation
- EEPROM permanently stores programming without battery backup

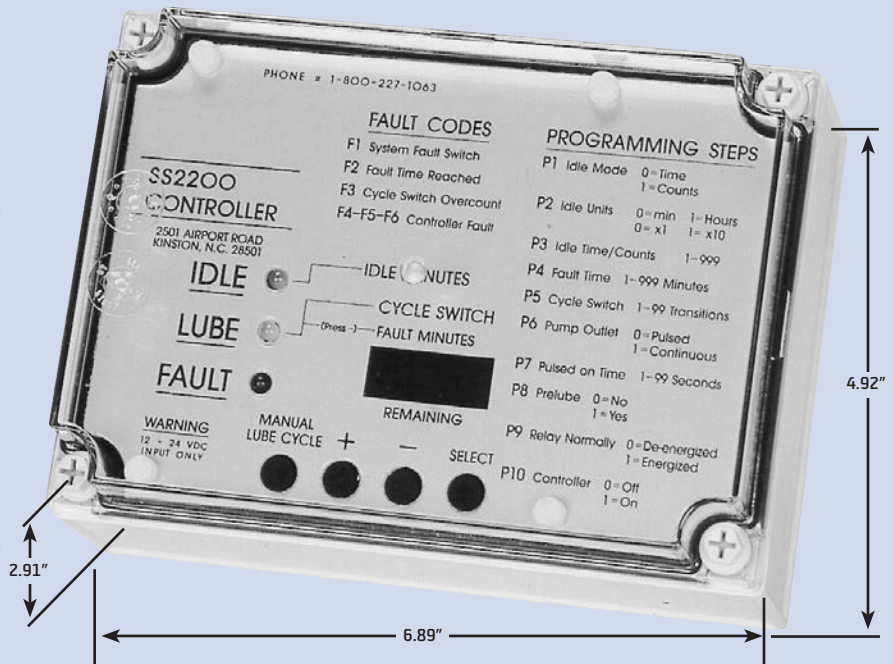

Specifications

Input	115 VAC - 50/60 Hz Over voltage protected
Outputs	Pump Pulsed or continuous, Form A, 115 VAC 5 amp, In-rush, 2 amp. continuous
	Cycle Switch 12-16 VDC, 12-16 ma.DC
	Fault Switches 12-16 VDC, 12-16 ma.DC
Fault Relay Contacts	2 amp, 125 VAC
Enclosure	NEMA 4x, Polycarbonate
Ambient Temperature	+20° F. TO 120° F.
Vibration	1.5 G
Permanent History	EEPROM (No Battery)

Programming

Idle Time	1-999 hours, 1-999 minutes 1-999 or 10-9990 machine counts
Cycle Completion Time	1-999 minutes
Cycle Switch Counts	1-99 counts
Pulsed Output On-Time	1-99 seconds
Prelube on Power-Up	Yes/No
Fault Relay	Normally energized/Normally de-energized
Controller	On-Off

Refer to the following documents for more info:

+ Datasheet #24735: SS2200-AC

System Controllers

General

The SC400 Controller is a full featured lubrication control, offering “two plus one” functionality. The controller has the ability to operate a single pump and two zone valves (e.g. frequent/ infrequent lubrication cycles) or two separate pumps (e.g. one oil pump & one grease pump). For single zone systems, the SC400 Controller also offers two intervals (e.g. weekday /weekend). The controller can activate a fill pump as needed to maintain proper fluid levels in the oil or grease reservoir.

Features

- 2 zone operation (for Progressive, Injector and Dualine Hydraulic systems)
- IP56 enclosure, constructed of molded polyester fiberglass
- CE approved
- Four supported languages (English, French, Spanish, German)

Technical Data

Input Voltage	85 to 265 VAC, 50/60 Hz
Idle Time Range	1 second to 100 days
Machine Cycle Counts	1 to 999,999 Counts (30 counts/second at 50% duty cycle)
Monitor Time	1 second to 24 hours
Cycle Counts On	1 to 999 counts
Over Counts	0 to 9
Net Weight	5 lb
Length x Width x Height	12.3" x 9.2" x 5"



Refer to the following documents for more info:

+ Datasheet #35980: SC400 Controller

General

The SMDC Controller is a multi-purpose programmable controller used with 12-24 VDC lubrication systems. Controller settings are saved whenever power is interrupted. Up to four operating modes can be selected which allows the controller to be used with various lubrication system designs. A voltage selector switch is located inside the enclosure for both 12 and 24 VDC service.

Features

- Digital status display on front cover for easy programming
- System monitoring capabilities (pressure switch and low level switch)

Technical Data

Operating Voltage	12VDC, 24VDC (factory setting)	
IP Enclosure Rating	External terminal strip	IP-47
	Liquid tight connector	IP-67
Ambient Temperature	-4 °F to 104 °F (-20C to 40 °C)	

How to Order

SMDC Controller	Description	Part Number
	Controller with external terminal strip	33346ME
	Controller with liquid tight connector	33346E



Refer to the following documents for more info:

+ Datasheet #46911: SMDC Controller

Controller Status LEDs

Red Steady	Lubrication cycle
Yellow Steady	Alarm
Green Steady	Power supply on
None Lit	No input to controller

System Controllers & Pressure Switches

General

The 32088 control panel is used with air operated lubrication systems (normally drum pumps).

Unit comprises a panel mounted SS2200 controller, pressure switch, pressure gauge and solenoid controlled air valve.

Specifications

Electrical Solenoid Valve (3/2 NC)	110/120V 50/60 Hz
Operating Pressure	150 psi
Holding Amps	.09
In-rush Amps	.12
Controller (See SS2200 page 25)	
Electrical Characteristics	115V 50/60 Hz

Refer to the following documents for more info:

+ Datasheet #32242: Control Panel

Model 32088

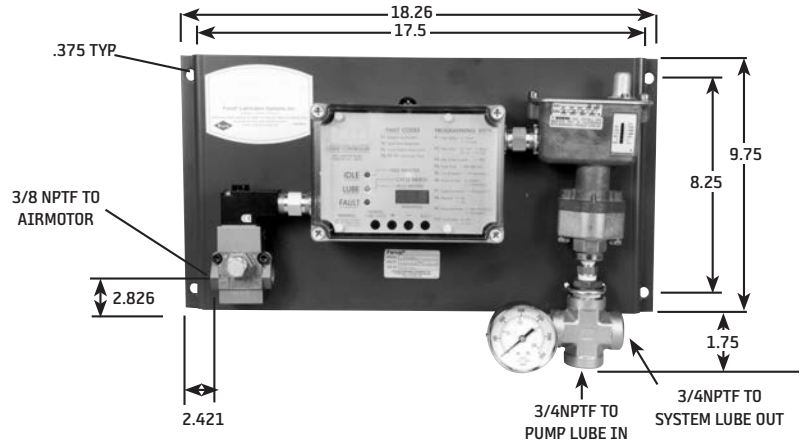

U620D1 Pressure Switch Single Pole Double Throw (Oil or Grease) (NEMA 3 enclosure)

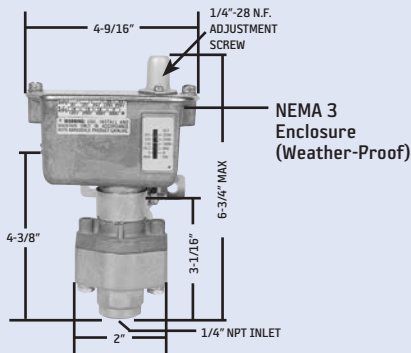

Part No.	Proof Pressure	Adjustable Range				Actuation Valve Differential Approx.
		Decreasing		Increasing		
		Min.	Max.	Min.	Max.	
U620D1	7000	250	2775	280	3000	30-225

ALL VALUES P.S.I.G.

Electrical rating (continuous inductive):

10 amps. 125, 250 or 460 V. AC., 15 amps. 6 V. DC.

Contact symbol:

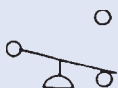

U623 Pressure Switch Single Pole Double Throw (Pneumatic)

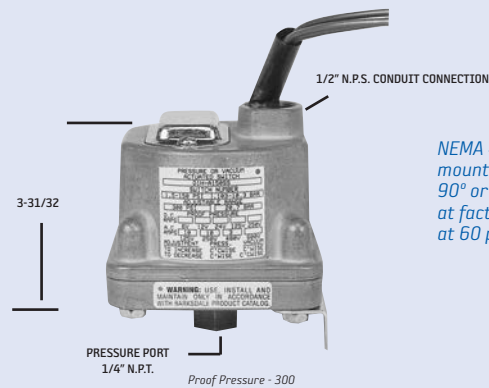

NEMA 4 enclosure (water tight) mounting bracket may be rotated 90° or 180° from position shown. Set at factory so that NC contacts close at 60 psi on decreasing pressure.

Adjustable Range				Actuation Valve Differential Approx.
Decreasing		Increasing		
Min.	Max.	Min.	Max.	
1.5	144.8	1.5	150	2.2 - 5.2

ALL VALUES P.S.I.G.

Electrical Rating (continuous inductive):

10 amps. 125 or 250 V. AC., 3 amps. 460 V. AC., 5 amps. 28 V. DC.

Contact Symbol:

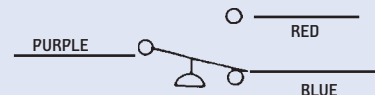

Wire Coding: Red = N.O., Blue = N.C., Purple = Common

Solenoid Valves

Solenoid Valve Specifications, Part No. 20311-3

Operating Data

Fluids	Air or inert gas
Lubrication	Not required
Ambient Temperature Range	0° to 140°F (-18° to 60°C)
Flow Rating, Cv (average)	0.18
Orifice	2.0 mm.
Pressure Range	150 psi max.
Inlet Connection Port	1/8" NPTF
Exhaust Port	1/8" NPTF
Outlet Connection Port	1/8" NPTF

Note: Valve body may be rotated 180° to reverse outlet port orientation.

Electrical

Voltage (V/Hz)	120/60; 110/50, 710%
Coil	Continuous duty, encapsulated Class F
Current	
In-rush	14.8 Volt - amps (0.12 amps)
Holding	10.9 Volt - amps (0.09 amps)
Connection	Connector pin assignment according to DIN 43650 Form A
Operation Mode	3 way, 2 position, normally closed

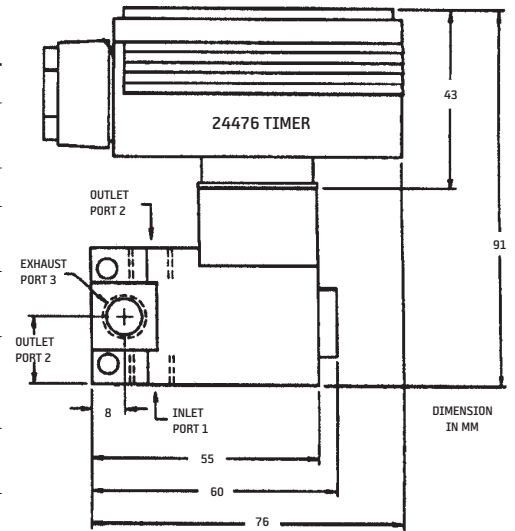

Dimensional Diagram of 24476 Timer and 20311-3 Sol. Valve (Sold Separately)



U10626 3-WAY, NC, Solenoid Valve (Pneumatic) (NEMA 4 Enclosure)

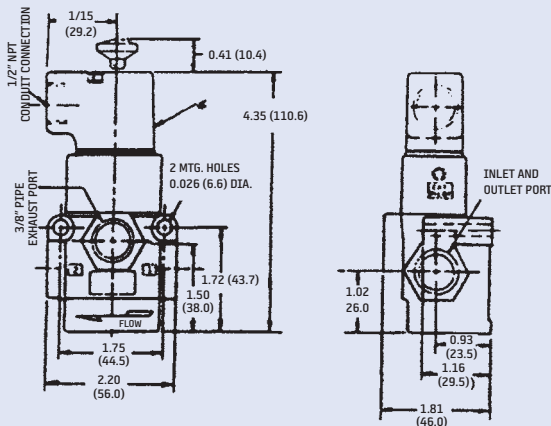

Part No.	Voltage	Hertz	CV Factor.	Action	Port Size (NPTF)
U10626A1	110/120 VAC	50/60	1.4	NC	1/4
U10626C1	110/120 VAC	50/60	1.6	NC	3/8
U10626A5	24 VDC	-	1.4	NC	1/4

Holding Current (amps)	.09
In-Rush (amps)	.12
Maximum Operating Pressure - 150 psi	

201594 2-WAY, NC, Solenoid Valve (Pneumatic) (NEMA 4X)

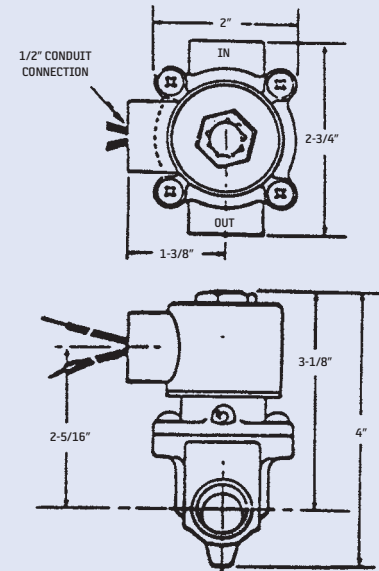

Part No.	Port Size (NPTF)	Orifice Size	CV Factor	Operating Pressure	Normal Valve Position
201594	1/2"	1/2"	2.81	5-150 psi	Closed

Volts (AC)	In-Rush (amps)	Holding (amps)
120	.14 at 50 Hz .12 at 60 Hz	.09 at 50 Hz .07 at 60 Hz

Injector and Bearing Point Monitors

General

The 55105 Lube Point Monitor is an accurate oval gear mechanism that incorporates two magnets into one of the nylon oval gears. The body incorporates a reed switch which senses the magnet passing. Lubricant entering the 55105 causes the gears to rotate. Each pulse equates to an approximate displacement of 0.040 cu.in.(.65cc). The monitoring of the 55105 is done with any PLC. The feedback from the 55105 will assure that lubrication has reached the inlet of the critical lubrication points.

Application

The 55105 Lube Point Monitor is intended to be mounted at or near the lubrication point inlet. It can be used with any type of grease or oil system (Dualine/Progressive/PDI). Due to the nature of the internals, proper filtration is required to keep contaminants out of the monitor body.

Technical Data

Flow	0-2500cc/min.
Maximum Pressure	10153 psi (700 bar)
Temperature	-4 °F to 158 °F (-20 C to 70 °C)
Connections	1/8"NPT
Material	Aluminum
Lubricant	ISO VG 32 to NLGI grade 2
IP Enclosure Rating	IP-67
Output Connection	4-pole M12X1 (male)
Switch Rating	0-24 VDC Max Voltage / 0.20 amp Max Current



Refer to the following documents for more info:

+ *Datasheet #35978: Lube Point Monitor*

Injector and Bearing Point Monitors

General

The FL Indicator Pin Monitor utilizes high quality sensors with built in LED's. The sensor will read movement of the FL PDI indicator during each lubrication cycle. This ensures that lubricant has reached the FL PDI. It will allow the user to monitor FL PDI/pin operation remotely from any PLC.

Application

The FL PDI Indicator Pin Monitor is available for any FL Series Injectors (FL30/40/1/11).

Technical Data - Sensor

Supply Voltage	10-30 VDC
Temperature	-13 °F to 158 °F (-25 C to 70 °C)
IP Rating	IP-67
Material	Stainless Steel V2A (housing)
Connection	S12 connector

How to Order

Name	Description	Part #
FL Indicator Pin Monitor Kit	For FL30/40	37297
	For FL1 (FL44)	37298
	For FL-11 (FL-45)	37299
Cable (Straight, 10 meters long)		76928-2863
Cable (90°, 10 meters long)		76928-2833

Note: Cables supplied seperately - can also be used with 55105



Refer to the following documents for more info:
+ [Datasheet #35966: FL Indicator Pin Monitor](#)

Pump Accessories



Manual Filling Pumps

- Model 37303 Manual Grease Fill Pump Kit: 120lb Drum
- Model 37304 Manual Grease Fill Pump Kit: 35lb Pail

Used to fill grease reservoirs & grease guns quickly and efficiently. Product mounts directly to original 120 lb. drum and 35 lb. pail. Included items: Cover, Follower Plate, Loader Coupler. Also includes a 6 foot hose (with fittings required to attach to pump and two fill couplers supplied for grease reservoirs), one female quick coupler for hydraulic stud (used on TTN reservoirs), one for standard fill stud (used on Multiport/CS2000 and TP type reservoirs). Develops: 500 psi Delivery: 1lb/6 strokes

Air Regulators and Gauges - Mounting Brackets



Model F976

1/2" Regulator with 0-250 psi range and 2", 0-160 pressure gauge.

Model F973

Same as F976 except 3/8"

Filters

Model F978

1/2" Filter

Model F975

3/8" Filter



Lubricators

Model F977

1/2" Lubricator

Model F974

3/8" Lubricator



Filter, Regulator, Lubricator Combo

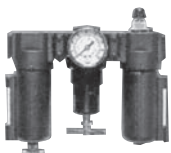

Model F985

1/2" Filter, Regulator (0-250 psi) gauge (2", 0-160 psi), lubricator.

Model F984

Same as F985 except 3/8"

Model F989

Mount kit for Combo units.

Mini Filter, Regulator, Lubricator Combo



Model F995

1/4" FRL combo

Model F991

1/4" Mini Regulator and Gauge

Model F993

1/4" Mini Filter

Model F996

Mini Wall Mount Bracket

Pump Hoist Part Number F111

For HD Series Pumps. Air-operated hoist lifts and lowers pumps for fast and easy drum changes. Hoist arm adjusts for different pump heights and swings a full 360°. Push/pull air valve controls hoist. Base bolts to floor. Can be used with other pumps by using a strap.

Unit height is 62-1/8" (lowered) and 98-5/8" (raised).

Air inlet is 1/4" NPTF (m).

Maximum air pressure is 150 psi.



Low level switch kit for 120/400 lb drums

Model LC10243 - for 120 lb drum

Model LC11036 - for 400 lb drum

Notes:

(1) Requires cover and follower plate - order separately.

(2) Customer/user to provide 15/16" hole in cover.

(3) Can be used with any style pump.

Pressure Gauge

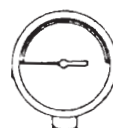

Fig. 1

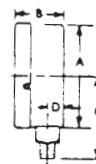

Fig. 2

Part No.	Fig. No.	Pipe Size (NPTF)	Press Range (psi & Kpa)	Dimensions				
				A	B	C	D	E
U902D	1	1/4	3000	2-5/8	1-1/4	2-1/4	13/32	
U902F	1	1/4	5000	2-5/8	1-1/4	2-1/4	13/32	
U902H	1	1/4	160	2-5/8	1-1/8	2-1/4	11/32	
U902J	1	1/4	2000	2-1/8	1-1/16	1-13/16	5/16	
U902DB	2	1/4	3000	2-5/8	1-1/4			15/16

Tubing & Fittings

Tubing

Part No.	Type	Size (in.) O.D. x Wall	Max. Working Pressure psi (bar)	Length (ft.)
27388	Steel	1/8 x .020	4700 (320)	25
27721		1/4 x .028	3300 (224)	25
U424E6		3/8 x .049	3000 (204)	16-24'
27722	Nylon	1/8 x .022	880 (60)	25
27389		1/8 x .022	880 (60)	100
21672		1/4 x .050	1000 (68)	100

Bulk feed line hose and fittings

Designed to easily fabricate any length flexible feed line. Hose end connections are assembled with standard tools.

Model 27729

25 ft. coil; 3/16" I.D. x 3/8" O.D. working pressure = 500 psig. Burst pressure = 2000 psig. Minimum bend radius = 2-1/2".
(Bulk Hose 27730 is available. Order any length in feet.)

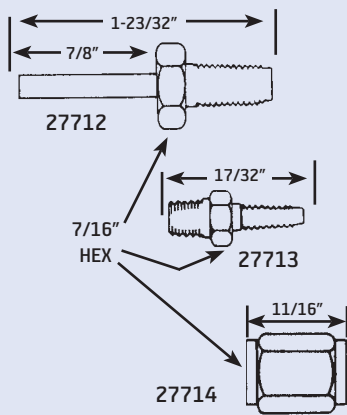

Hose End Fittings

Part No.	Type	Description	Size (in.)
27712	Steel	Hose Stud	1/8 O.D. tube x 1/4-28 male
27713		Hose Stud	1/8 NPT male x 1/4-28 male
27714		Coupling Nut	1/4-28 female
27715	Stainless Steel	Hose Stud	1/8 NPT male x 1/4-28 male
27716		Coupling Nut	1/4-28 female

Feed line hose

Series 27740-27743

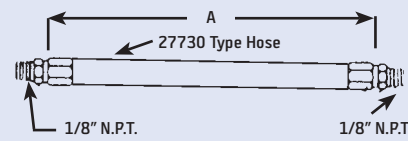

Series 27733-27739

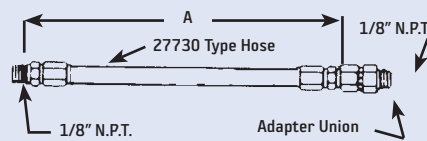

Part No.	"A" (in.)	Description
27740	12	1/8" NPT male end connections
27741	18	
27742	24	
27743	30	
27733	6	1/8" NPT male at one end and swivel adapter union 1/8" NPT male at other end
27734	8	
27735	12	
27736	18	
27737	24	
27738	30	
27739	36	

Tube Clamps

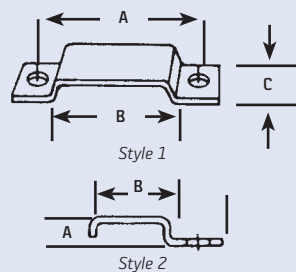

Clamp No.	Const.	No. Tubes	Tube Size (in.)	A (in.)	B (in.)	C (in.)	Style
27820-1	Steel	1	1/8 O.D.	-	1/8	3/8	1
27820-2		2		11/16	1/4	3/8	
27820-3		3		13/16	3/8	3/8	
27820-4		4		15/16	1/2	3/8	
27820-5		5		1-1/16	5/8	3/8	
U301B1	Steel	1	1/4 O.D.	5/16	3/8	3/4	2
U301B2		2		5/16	5/8	3/4	
U301B3		3		5/16	7/8	3/4	
U1301B4	Steel	4	1/4 O.D.	5/16	1-1/8	1/2	1
U1301B6		6		5/16	1-5/8	1/2	
27821-1		1		-	1/8	3/8	
27821-2	2	11/16	1/4	3/8			
27821-3	3	13/16	3/8	3/8			
27821-5	5	1-1/16	5/8	3/8			

Tube Fittings

Straight Connector, Tube to Male Pipe

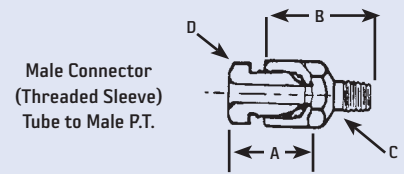

Part No.	Tube O.D. (in.)	Pipe Thread (in.)	A (in.)	B (in.)	Hex. C (in.)	Hex. D (in.)
27727	1/8	1/4-28	1/2	5/8	3/8	5/16
27726	1/8	1/8 NPT	1/2	5/8	7/16	5/16

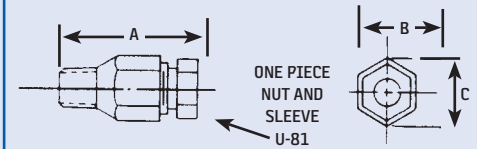

Tube Size	Part No.	Male Pipe Thread (NPTF)	Dimensions		
			A	B	C
1/4	U-83-B1	1/8	1-1/8	1/2	.577
1/4	U-83-B2	1/4	1-1/8	5/8	.721
1/4	U-82-B3	3/8	1-1/8	3/4	.865
3/8	U-83-D1	1/8	1-3/4	3/4	.865
3/8	U-83-D2	1/4	1-3/4	3/4	.865
3/8	U-83-D3	3/8	1-9/16	3/4	.865

90° Elbow, Tube to Male Pipe

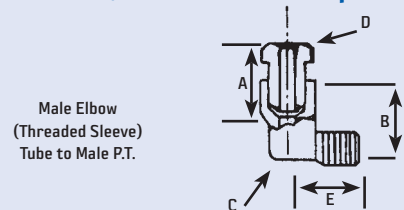

Part No.	Tube O.D. (in.)	Pipe Thread (in.)	A (in.)	B (in.)	Hex. C (in.)	Hex. D (in.)	E (in.)
27728	1/8	1/4-28	1/2	1/2	13/32	5/16	33/64
27725	1/8	1/8 NPT	1/2	1/2	7/16	5/16	21/32

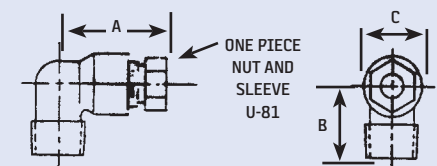

Tube Size	Part No.	Male Pipe Thread (NPTF)	Dimensions		
			A	B	C
1/4	U-87-B1	1/8	1-1/8	7/8	19/32
1/4	U-87-B2	1/4	1-1/8	7/8	19/32
1/4	U-87-B3	3/8	1-1/4	31/32	13/16
3/8	U-87-D1	1/8	1-7/16	31/32	13/16
3/8	U-87-D2	1/4	1-7/16	31/32	13/16
3/8	U-87-D3	3/8	1-7/16	31/32	13/16

Innovators of engineered lubrication technology **since 1923**

Bijur Delimon International has ISO 9001:2000 and ISO 14001:2000 quality certified manufacturing facilities around the world, so your centralized lubrication system meets the highest industry quality standards. It's all part of our commitment to quality and customer service.



BIJUR DELIMON NORTH AMERICA
2250 Perimeter Park Drive, Suite 120
Morrisville, NC 27560

(252) 527 6001 **LOCAL**
(800) 227 1063 **TOLL-FREE**
(252) 527 3533 **FAX**

WWW.BIJURDELIMON.COM

414 • R21 08/17